

GENERAL PRODUCT OVERVIEW



Nailor
Industries Inc.

GENERAL PRODUCT OVERVIEW

Nailor provides a complete line of products with industry leading performance and quality features uniquely suited to underfloor air distribution systems. Architecturally appealing raised access floor diffusers for interior and perimeter zones as well as VAV diffusers are engineered to provide superior comfort levels while allowing maximum flexibility for occupant adjustments. Our super quiet fan powered terminal units and fan coil units are specifically designed for low height underfloor applications. Eminently suitable for the most demanding applications they incorporate ultra-high efficiency features such as ECM™ motors, our patented EPIC Fan Technology® and low pressure drop inclined opposed blade dampers.

FLOOR "SWIRL" DIFFUSER

Model NFD Floor "Swirl" Diffusers are designed for use in raised access floor air distribution systems, where the floor cavity is used as a pressurized supply air plenum. The NFD core design produces a low velocity helical "swirl" discharge air pattern. The design achieves high induction rates of room air which optimizes mixing for maximum comfort conditions.

An architecturally appealing face design compliments any contemporary decor and is available as standard in a gray or black finish as well as a wide variety of custom colors.

Allowing extreme flexibility in space planning, the diffuser, once installed in the access floor panel, can be quickly relocated to accommodate changing conditions and floor layouts.

Model NFD

See page B3

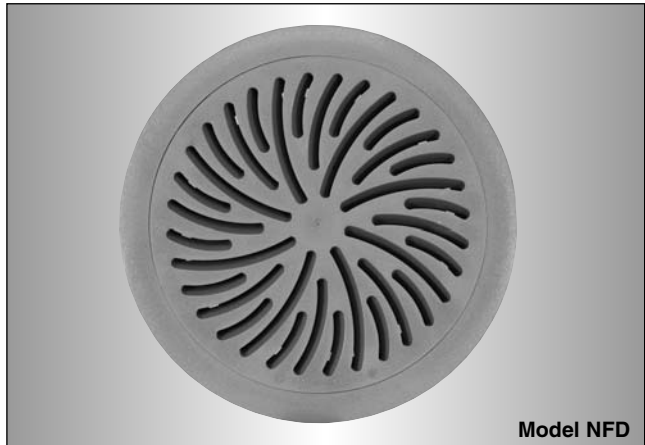

Model NFD

ALUMINUM FLOOR "SWIRL" DIFFUSER

Model ANFD Aluminum Floor "Swirl" Diffusers are designed for use in raised access floor air distribution systems, where the floor cavity is used as a pressurized supply air plenum. The specially designed ANFD core produces a low velocity helical "swirl" air pattern. This design achieves high induction rates of room air which optimizes mixing for maximum comfort conditions.

An architecturally appealing face design compliments any contemporary decor and is available as standard in a gray or black textured finish as well as a wide variety of custom colors.

Allowing extreme flexibility in space planning, the diffuser, once installed in the access floor panel, can be quickly relocated to accommodate changing conditions and floor layouts.

Model ANFD

See page B7



Model ANFD

FLOOR ACCESS OUTLET

Model NFA Floor Access Outlets are designed for use in raised access floor air distribution systems and compliments the Model NFD Floor "Swirl" Diffuser. It provides a functional means of through-the-floor routing of electrical, telephone and data communication cables.

An architecturally appealing face design compliments any contemporary decor and is available as standard in a gray or black finish as well as a wide variety of custom colors.

Allowing extreme flexibility in space planning, the floor access outlet, once installed in the access floor panel, can be quickly relocated to accommodate changing conditions and floor layouts.

Model NFA

See page B12

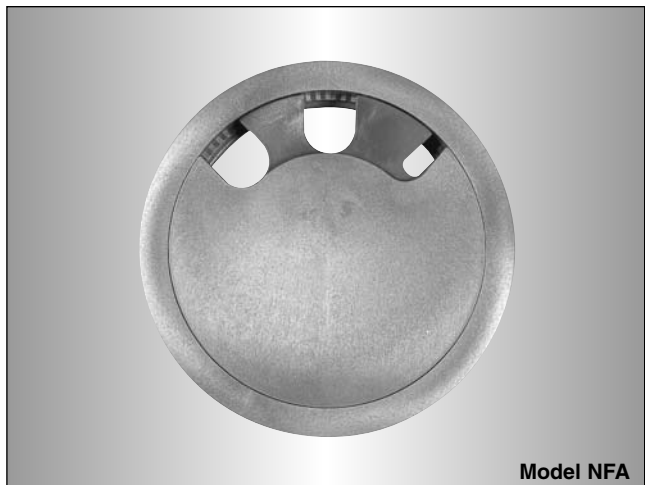

Model NFA

A

GENERAL PRODUCT OVERVIEW

VAV FLOOR "SWIRL" DIFFUSER WITH ACTUATOR

Model NFD-VAV Floor "Swirl" Diffusers with actuators are designed for use in raised access floor air distribution systems, where the floor cavity is used as a pressurized supply air plenum. An integral modulating actuator provides variable air volume control in cooling applications for precise zone temperature control. The NFD-VAV core design produces a low velocity helical "swirl" discharge air pattern. The design achieves high induction rates of room air, which optimizes mixing for maximum comfort conditions.

An architecturally appealing face design compliments any contemporary decor and is available as standard in a gray or black finish as well as a wide variety of custom colors.

Allowing extreme flexibility in space planning, the diffuser, once installed in the access floor panel, can be quickly relocated to accommodate changing conditions and floor layouts.

Model NFD-VAV

See page B14



Model NFD-VAV



Model ANFD-VAV

VAV ALUMINUM FLOOR "SWIRL" DIFFUSER WITH ACTUATOR

Model ANFD-VAV Aluminum Floor "Swirl" Diffusers with actuators are designed for use in raised access floor air distribution systems, where the floor cavity is used as a pressurized supply air plenum. An integral modulating actuator provides variable air volume control in cooling applications for precise zone temperature control. The core design produces a low velocity helical "swirl" discharge air pattern. The design achieves high induction rates of room air, which optimizes mixing for maximum comfort conditions.

An architecturally appealing face design compliments any contemporary decor and is available as standard in a gray or black textured finish as well as a wide variety of custom colors.

Allowing extreme flexibility in space planning, the diffuser, once installed in the access floor panel, can be quickly relocated to accommodate changing conditions and floor layouts.

Model ANFD-VAV

See page B17

VAV LINEAR FLOOR DIFFUSER WITH ACTUATOR

Model Series NLD VAV Linear Floor Diffusers with actuators are designed for use in raised access floor air distribution systems. High quality, heavy duty, extruded aluminum linear grilles are featured providing an architecturally appealing face design that compliments contemporary decor. Heavy gauge steel plenums incorporate a large dust/dirt collection area that catches anything that might fall through the diffuser face.

Model Series NLD provides variable air volume heating or cooling control for ducted or non-ducted applications. A 90° rotation low leakage damper and integral modulating actuator provide precise airflow control.

Models NLD-VC, NLD-VH, NLD-VCD, NLD-VHD, NLD-VCHD, and NLD-VHCD

See page C3



Model Series NLD

VAV LINEAR FLOOR DIFFUSER WITH ACTUATOR

Model Series NLYD VAV Linear Floor Diffusers with actuators are designed for use in raised access floor air distribution systems. High quality, heavy duty, extruded aluminum linear grilles are featured providing an architecturally appealing face design that compliments contemporary decor. Heavy gauge steel plenums incorporate a dust/dirt collection area that catches anything that might fall through the diffuser face.

Model Series NLYD provides either variable air volume heating or cooling only control for non-ducted (pressurized access floor) applications. A 90° rotation low leakage damper and integral modulating actuator provide precise airflow control.

Models NLYD-VC, and NLYD-VH

See page C10



Model Series NLYD

A

GENERAL PRODUCT OVERVIEW

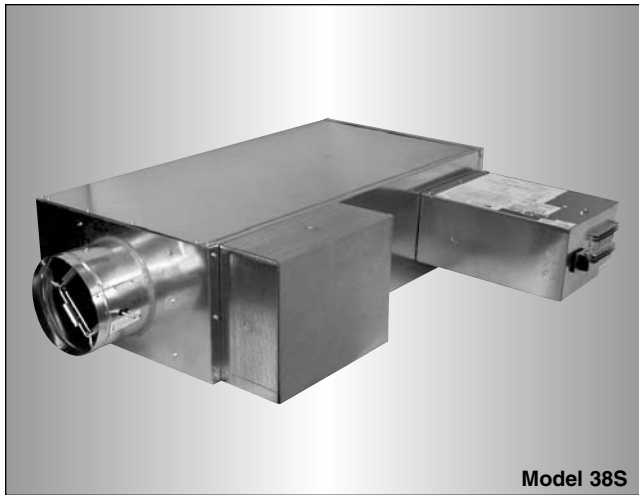

Model 38S

UNDERFLOOR FAN POWERED TERMINAL UNITS

Model Series 38S Underfloor Fan Powered Terminal Units are specially engineered to meet the requirements of the most demanding underfloor applications where premium quality design and performance characteristics are desired. Features include an inclined opposed blade damper and our multi-point averaging 'Diamond Flow' sensor to provide precise airflow control and excellent sound performance. Compact, low profile unit casings, designed to accommodate the floor pedestal layout, feature convenient access to all components.

Designed to optimize energy efficiency the standard units feature ultra-high efficiency EPIC™/ECM motor technology. Additional options include electric or hot water supplementary heat, and various 'IAQ' linings including a solid metal liner.

Models 38S, 38SW and 38SE

See page D3

UNDERFLOOR FAN COIL UNITS

Model Series 38F Underfloor Fan Coil Units are specially engineered to meet the requirements of the most demanding underfloor applications where premium quality design and performance characteristics are desired. These compact low profile units feature excellent sound performance, independently tested and certified. Heavy gauge unit casings, designed to accommodate the floor pedestal layout, feature convenient access to all components.

Designed to optimize energy efficiency the standard units feature ultra-high efficiency EPIC™/ECM motor technology. Additional options include two or four pipe water coils, electric heating coils, and various 'IAQ' linings including a solid metal liner.

Models 38F, 38FZ, 38FW, 38FZW, 38FE, 38FZE, 38FWE and 38FZWE

See page E3

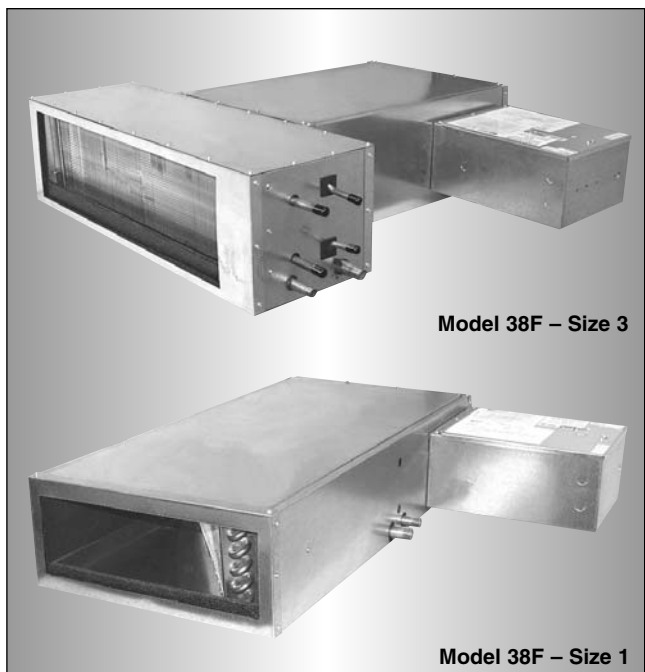

Model 38F – Size 3

Model 38F – Size 1