

GMAMCO

ACCESS PANEL

ADH-N

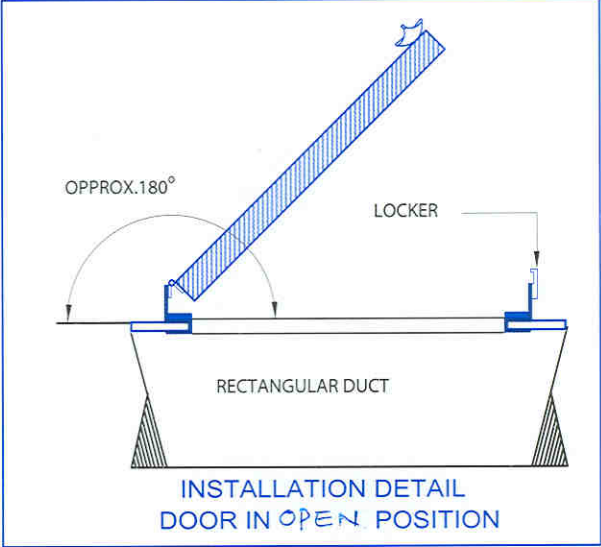
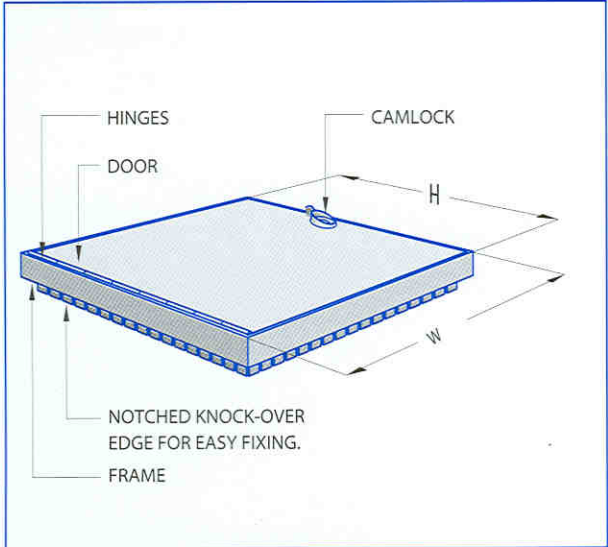

SPECIFICATIONS:

DOOR:
MADE OF GALVANIZED STEEL ga.22, DOUBLE SKIN AND WITH INTERNAL INSULATION. (SEE SECTION DETAIL).

DOOR FRAME:
GALVANIZED STEEL ga.22, ROLLER FORMED. PROVIDED WITH FOAM GASKET ALL AROUND, BOTTOM EDGE WILL BE NOTCHED KNOCK OVER FOR EASY FIXING UNTO THE DUCT.

CAMLOCK:
HOT ROLLED STEEL CAMLOCK. USE 1 PIECE OF CAMLOCK ONLY ON DOOR SIZE (H) UP TO 300mm ONLY.

HINGES:
SELF-OILING HINGES, SPOT WELDED UNTO THE FRAME.

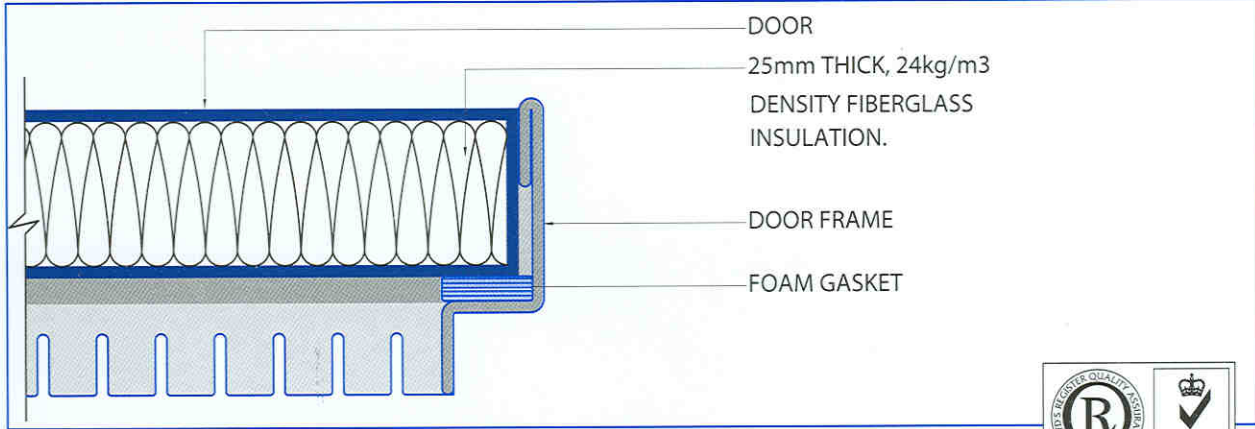
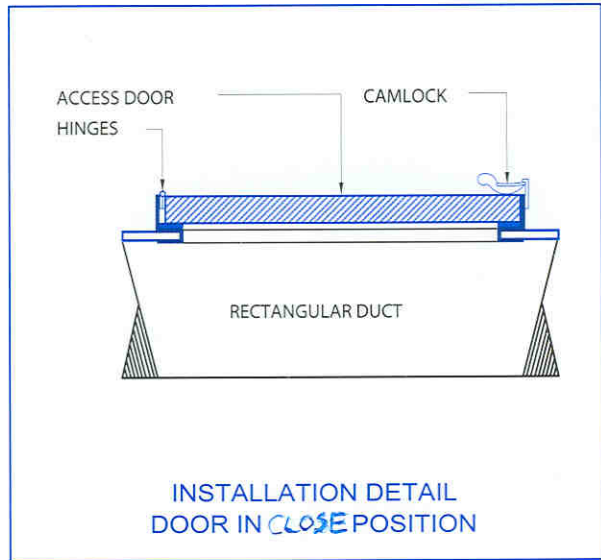

● **NOTE:** MAXIMUM SIZE FOR NORMAL WITH ABOVE SPECIFICATION TYPE IS 600mmx600mm.



ACCESS PANEL

SIZE SELECTION AND INSTALLATION METHOD

THE ADF SERIES OF SQUARE/RECTANGULAR ACCESS DOORS ARE OFFERED IN 17 STANDARD SIZES, TO PROVIDE A QUICK AND EFFICIENT MEANS OF ACCESS TO INDUCT ITEMS SUCH AS FIRE OR CONTROL DAMPERS AND FILTERS.

THE RANGE OF SIZES ALLOW FOR HAND OR SIGHT ACCESS.

THE STANDARD UNIT IS MANUFACTURED FROM GALVANISED SHEET STEEL AND DOUBLE SKINNED CONSTRUCTION 25mm THICK, INCORPORATING A 25kg/m³ THERMAL AND ACOUSTIC INSULATION.

SIZE SELECTION

DOOR SIZE (mm)	CUT HOLE SIZE (mm)	DOOR SIZE (mm)	CUT HOLE SIZE (mm)
100x100	70x70	250x250	220x220
100x150	70x120	300x300	270x270
100x200	70x170	300x450	270x420
150x150	120x120	300x600	270x570
150x200	120x170	400x400	370x370
150x300	120x270	400x600	370x570
200x200	170x170	450x450	420x420
200x300	170x270	600x600	570x570
200x400	170x370		

INSTALLATION METHOD

CUT A HOLE IN THE DUCT 30mm UNDER UNIT SIZE (eg. 150mmx150mm UNIT HOLE SIZE 120mm x120mm). FIT FRAME INTO HOLE AND WHILST COMPRESSING FOAM GASKET, KNOCK OVER THE EDGE TABS USING A DOLLY AND HAMMER AS SHOWN ABOVE.

VARIATIONS

- 1- EXTERNAL FLANGES TO RETAIN DUCT INSTALLATION.
- 2- 50mm (2") THICK CONSTRUCTION.
- 3- HINGE DOORS.
- 4- ALTERNATIVE SIZES FOR QUANTITY PURCHASES.



GMAMCO

ACCESS PANEL

ADF SERIES

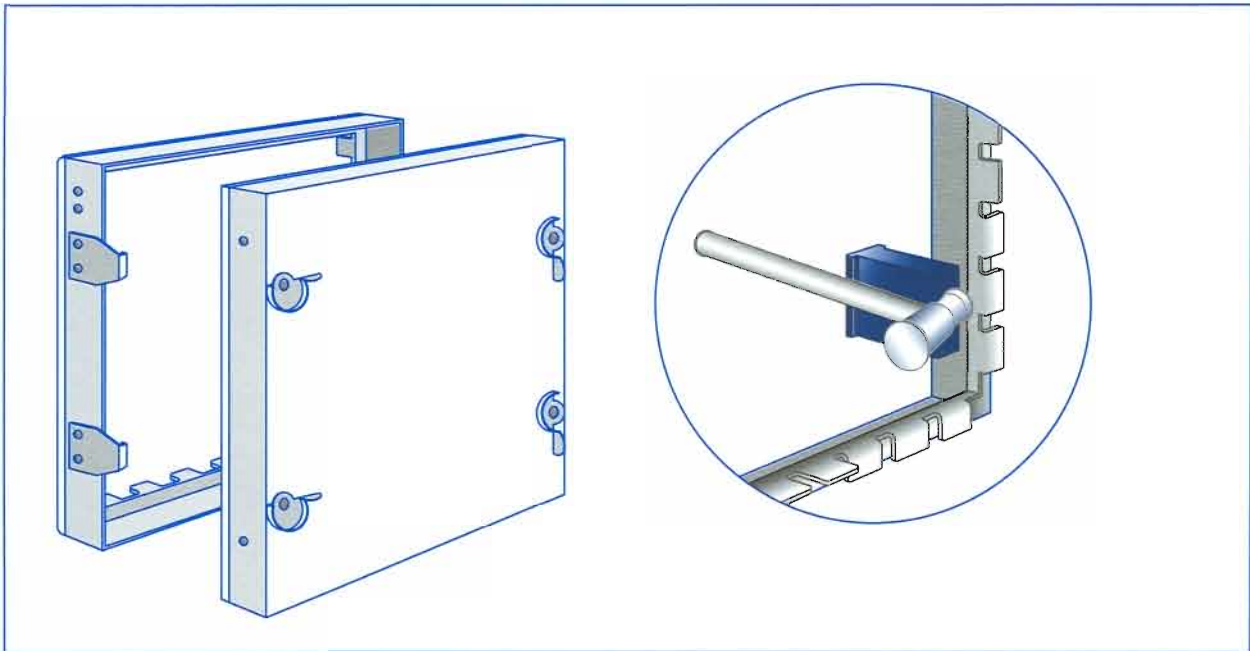

SPECIFICATIONS:

DOOR:

MADE OF GALVANIZED STEEL ga.22, DOUBLE SKIN AND WITH INTERNAL INSULATION. (SEE SECTION DETAIL).

DOOR FRAME:

GALVANIZED STEEL ga.22, ROLLER FORMED. PROVIDED WITH FOAM GASKET ALL AROUND, BOTTOM EDGE WILL BE NOTCHED KNOCK OVER FOR EASY FIXING UNTO THE DUCT.

CAMLOCK:

HOT ROLLED STEEL CAMLOCK. 2.NO'S CAMLOCK UP TO THE SIZE 300x300 AND 4.NO'S CAMLOCK ABOVE 300x300.

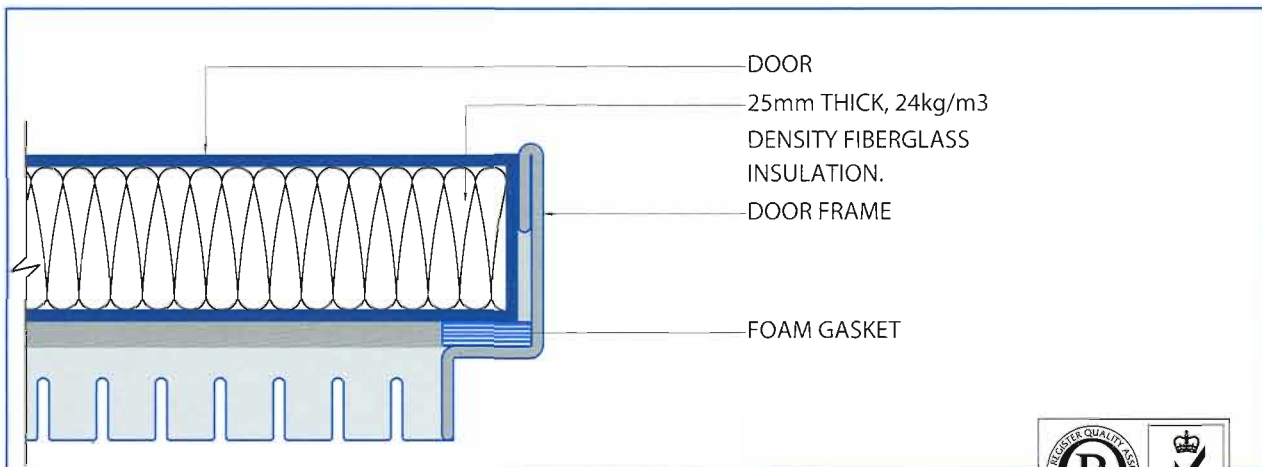

NOTE: MAXIMUM SIZE FOR NORMAL WITH ABOVE SPECIFICATION
TYPE IS 600mmx600mm.

